

Lexan Thermoclear applications in detail



Ampelite Australia Pty Ltd
ABN 91 487 122 629

VIC & TAS Tel 03 8710 9110 Fax 03 9794 0710

QLD Tel 07 3382 8300 Fax 07 3200 8703

SA & NT Tel 08 8260 7391 Fax 08 8260 7397

NZ Tel 09 634 5366 Fax 09 622 2060

NSW & ACT Tel 02 9625 7200 Fax 02 9625 7211

Nth QLD Tel 07 4774 5007 Fax 07 4774 7898

WA Tel 08 9302 6833 Fax 08 9302 6855

www.ampelite.com.au



Ampelite Lexan Thermoclear

The Lexan Thermoclear sheets are available in 10mm and 16mm gauges. The 10mm sheeting is offered in 700mm and 1050mm wide up to 7.0m in length. The 16mm sheeting is offered in 1050mm wide up to 6.0m in length. Additionally 2100mm wide sheeting in both 10mm and 16mm is stocked. Please contact ampelite for Availability. The sheeting can be easily cut to any required width on site. Sheet length can be cut back easily on site or factory cut prior to delivery.

All sheeting mentioned is stocked locally and is available in small or large quantities.

To minimise waste and avert incorrect installation the sheeting is UV protected on both sides.

This guide is to be used in conjunction with the H-bar and/or Flexibar installation instructions.

The Lexan Thermoclear sheet profiles are:

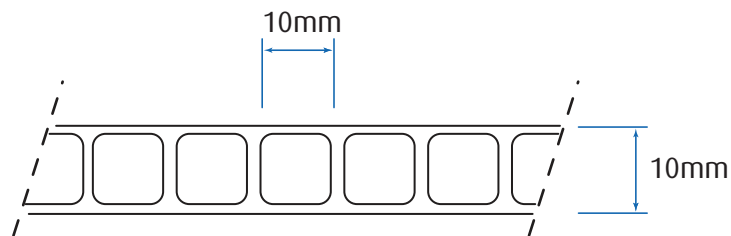

Lexan Thermoclear 10mm 2 RS
(LT2UV102RS17)

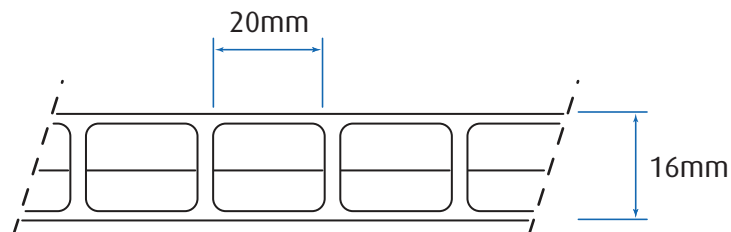

Lexan Thermoclear 163TS
(LT2UV163TS27)

Accessories

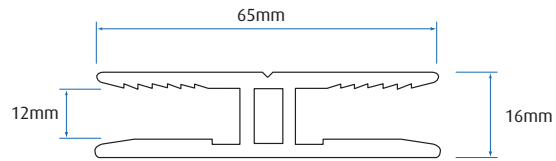

Aluminium H-bar to suit
10mm gauge

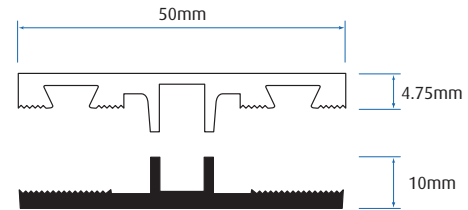

Flexibar

Top = aluminium;
7.0m maximum length

Bottom = rafter rubber gasket;
14.0m rolls

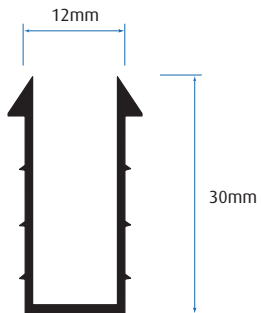

H-Bar rubber Gasket to suit
10mm gauge
14.0m rolls

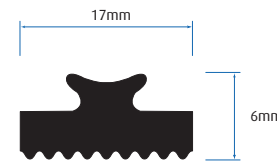

Flexibar rubber glazing gasket
14.0m rolls

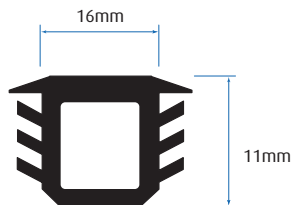

H-Bar finishing rubber to suit
10mm gauge
14.0m rolls

Accessories

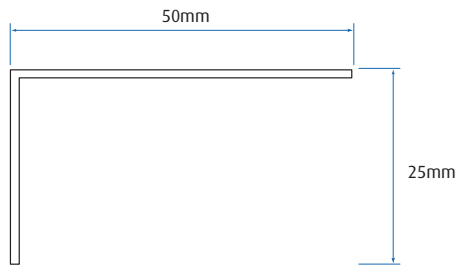

Flexibar Glazing Bracket

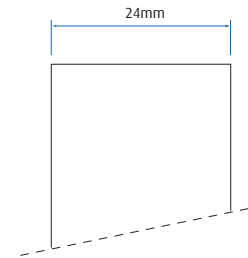

Aluminium Reinforced Sealer Tape
50.0m rolls

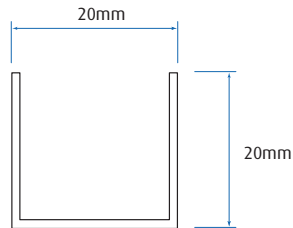

Aluminium End Cap to suit 10mm gauge
6.5m maximum length

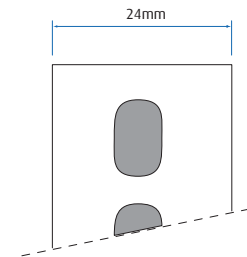

Aluminium Breather Tape
33.0m rolls

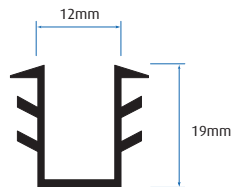

End Cap Rubber Gasket to suit 10mm gauge
14.0m rolls

Accessories

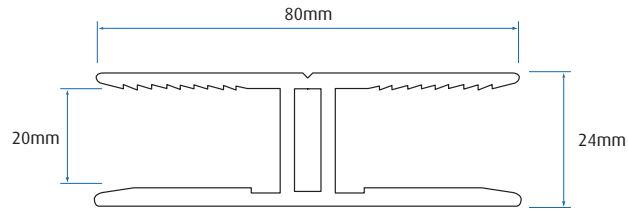

Aluminium H-Bar to suit
16mm gauge
7.0m maximum length

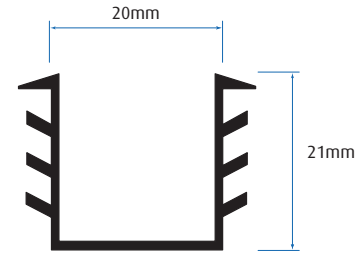

End Cap rubber gasket to suit
16mm gauge
14.0m rolls

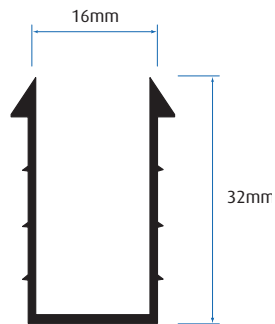

H-bar rubber gasket to suit
16mm gauge
14.0m rolls

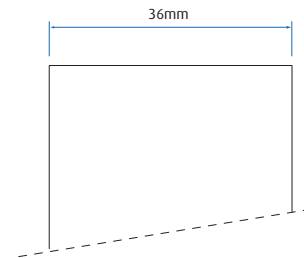

Aluminium Reinforced Sealer tape
50.0m rolls

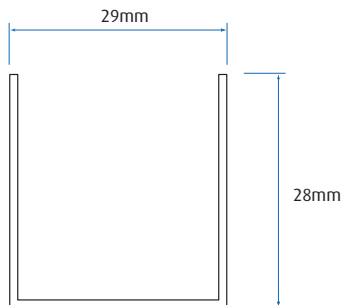

Aluminium End Cap to suit
16mm gauge
6.5m maximum length

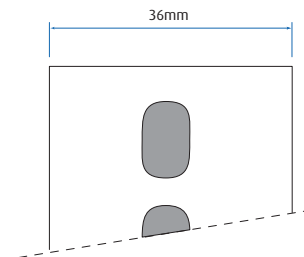

Aluminium Breather Tape
33.0m rolls

Accessories

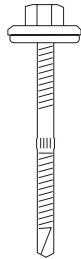

12 gauge x 35mm Tek screw

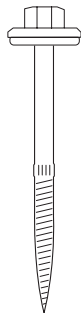

12 gauge x 50mm T17 screw

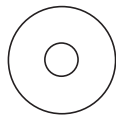

25mm Bonded Washer

Accessories

FIGURE 1: 10mm AND 16mm H-BAR

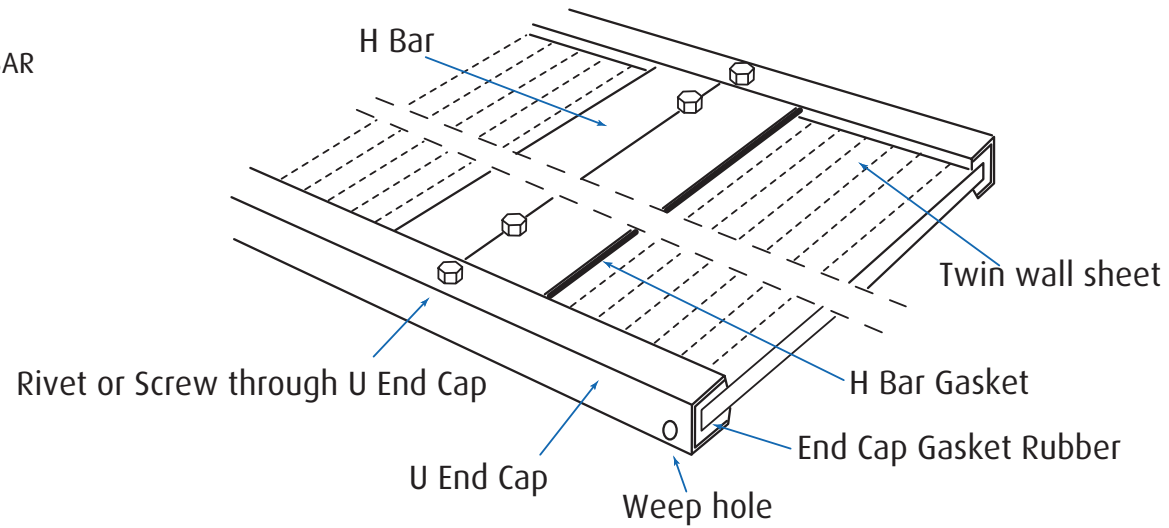
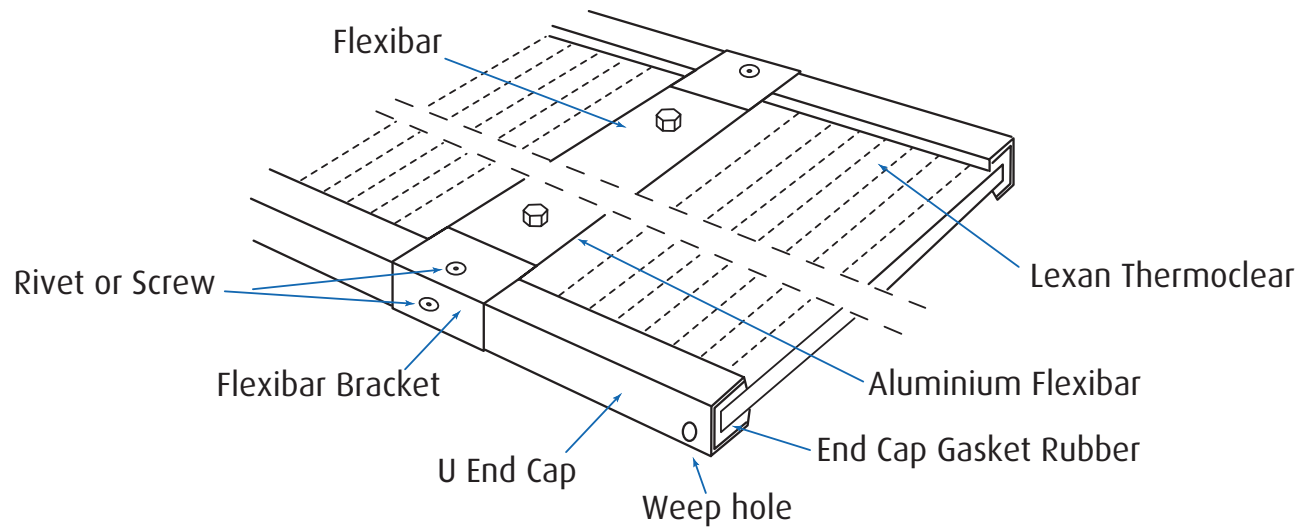

FIGURE 2: FLEXIBAR (for curved applications)
10mm and 16mm



Ampelite Lexan Thermoclear

The Lexan[®] Thermoclear[®] sheeting and accessories are versatile in function. Commonly used for external or internal applications straight or curved in roofing or wall cladding. The sheeting is made from quality Lexan[®] resin. All accessories are manufactured locally in Australia.

Lexan[®] Thermoclear[®] is a high quality low maintenance glazing material that is built to last. It delivers high impact strength, an excellent balance of low weight and high stiffness and naturally “water - clear” transparency. Air is trapped between layers providing outstanding insulating performance.

In typical applications the Lexan[®] Thermoclear[®] sheeting is joined by the aluminium H-Bar or Flexibar. Both these options provide a weatherproof system. To eradicate moisture, dirt and insect entry in typical applications the sheets are sealed with an aluminium tape on the top end and aluminium breather tape on the bottom end.

Both systems will only require fixings through the sheeting in high wind areas. When fixing through the sheeting a 10mm allowance at all fixing points is required to allow for expansion and contraction. An oversize 25mm bonded washer must be used when doing so. In typical applications every effort should be made to avoid fixing through the sheets.

Fixings will be 12 gauge 50mm Type 17 screw for timber and a 12 gauge 35mm Tek screw for steel. Cyclonic areas require 14 gauge. Please contact Ampelite for spanning and fixing in cyclonic areas.

Expansion and contraction allowance for non typical applications (not using the Ampelite system) must be allowed at 3mm per metre of sheet.

It is highly recommended for all cladding applications that the sheeting runs vertical. For all roofing applications the longitudinal flutes of the sheeting must run in the direction of the fall.

For typical H-bar installations the sheet run will start and finish with an H-bar. The void side of the H-bar will be filled with the H-bar finishing rubber gasket.

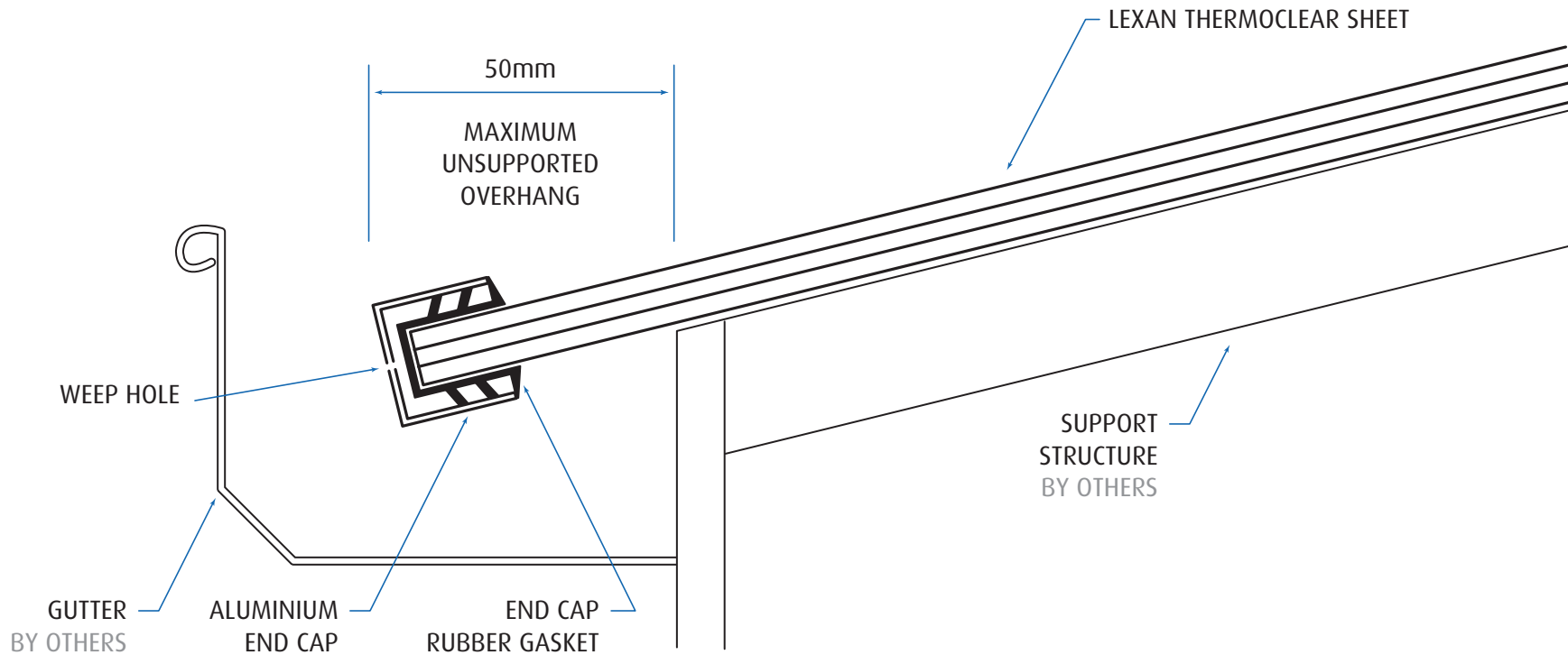

Lexan Thermoclear 10mm & 16mm Eave Detail

May 2011

DRAWN - MM

© Ampelite 2011

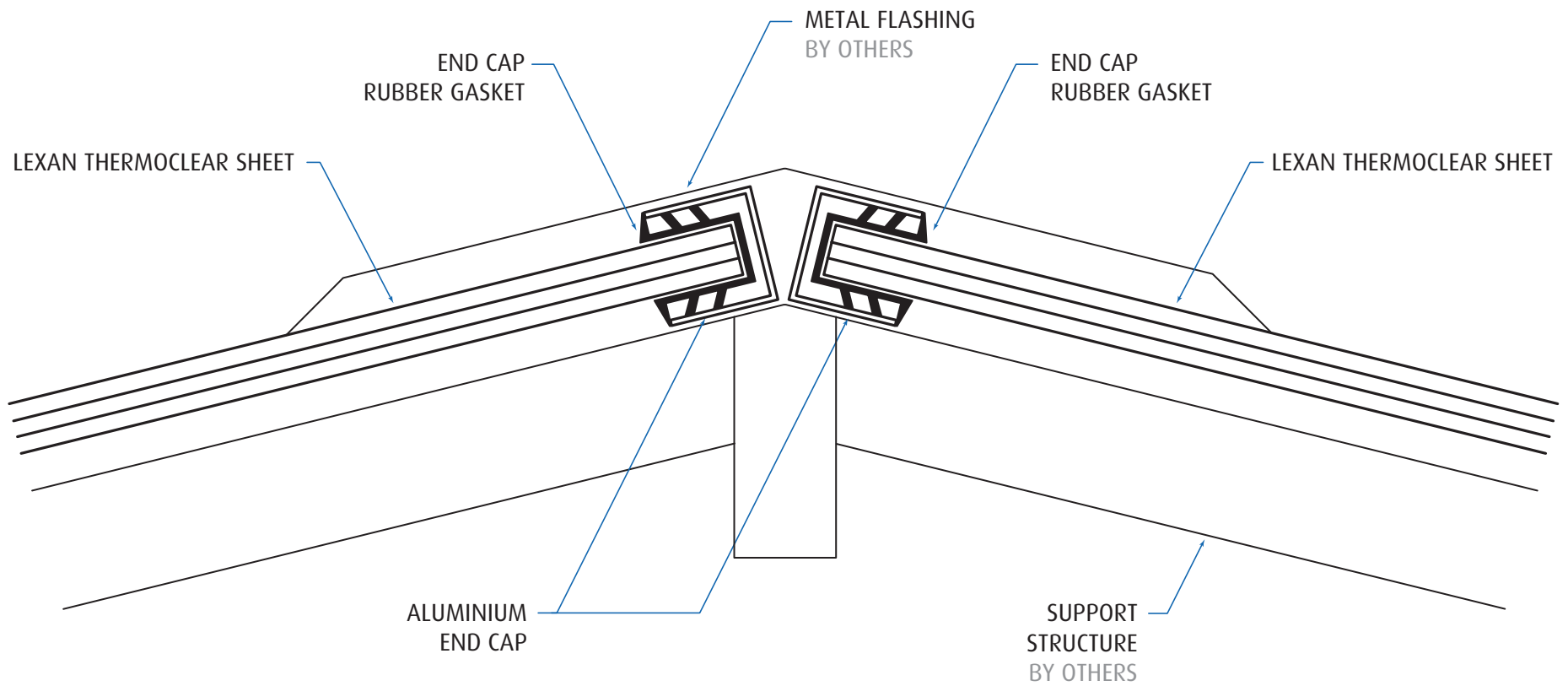

Lexan Thermoclear 10mm & 16mm Ridge Detail

May 2011

DRAWN - MM

© Ampelite 2011

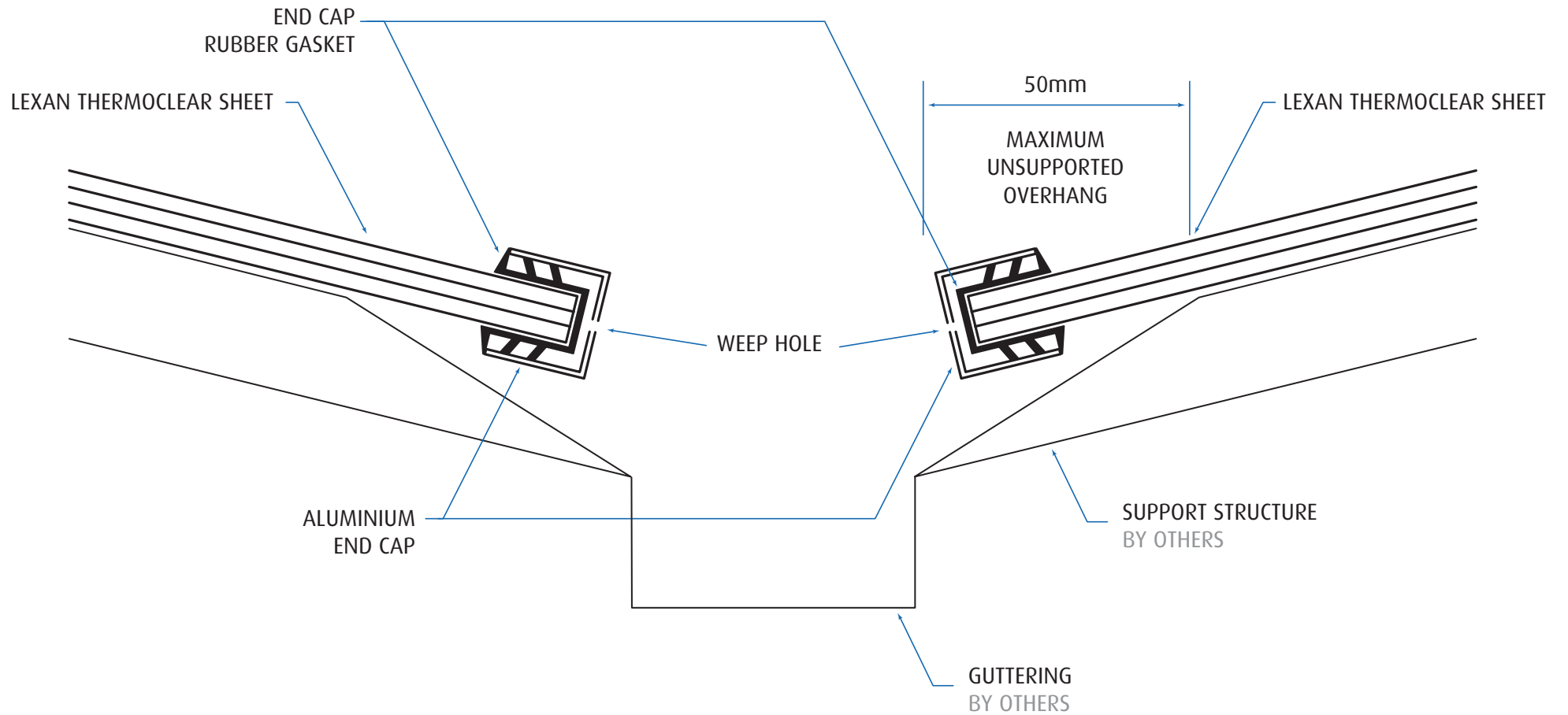

Lexan Thermoclear 10mm & 16mm Valley Gutter Detail

May 2011

DRAWN - MM

© Ampelite 2011

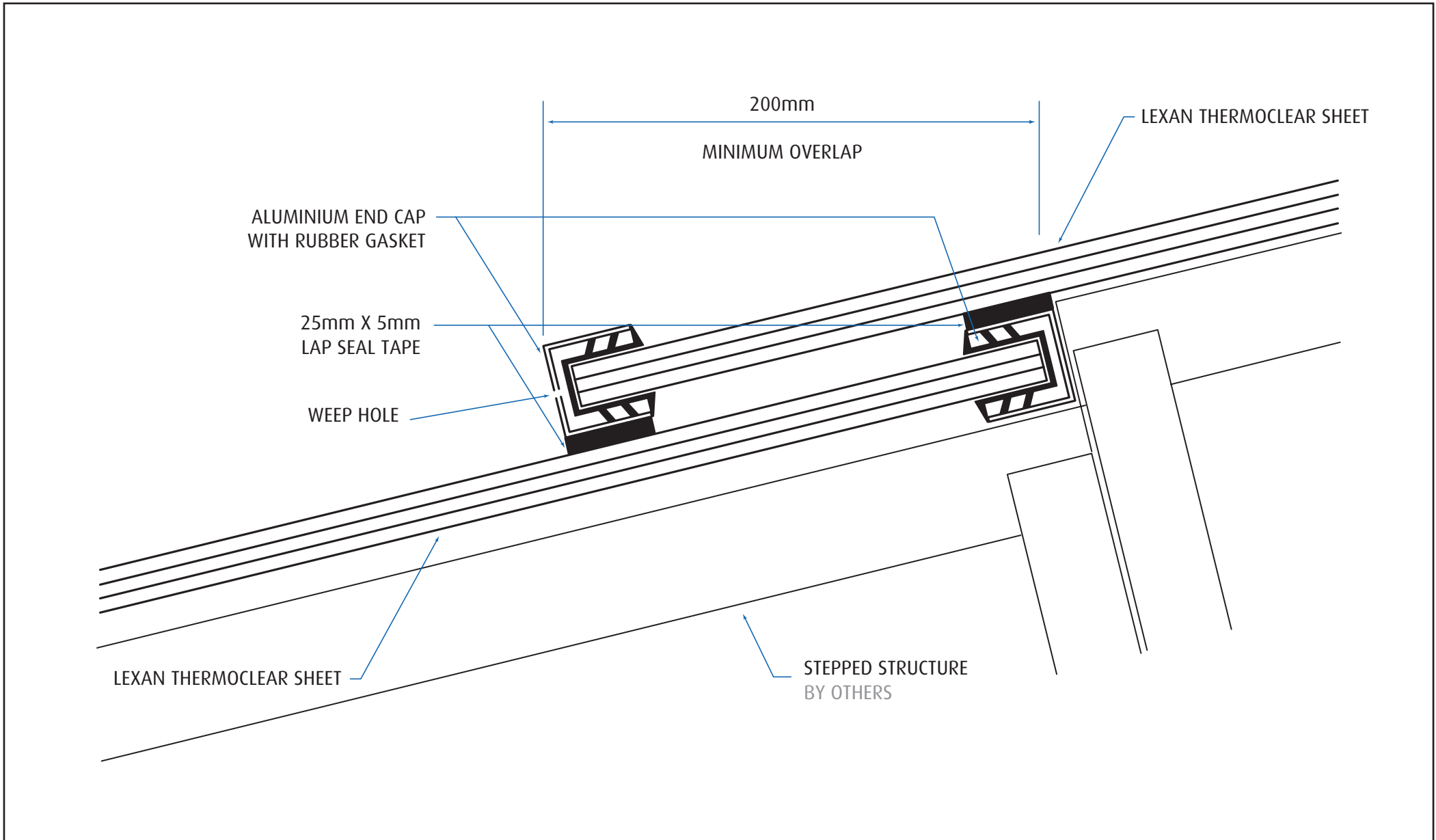

Lexan Thermoclear 10mm & 16mm Sheet Overlap Joint Detail

May 2011

DRAWN - MM

© Ampelite 2011

ALUMINIUM END CAP
WITH RUBBER GASKET

METAL FLASHING
BY OTHERS

LEXAN THERMOCLEAR SHEET

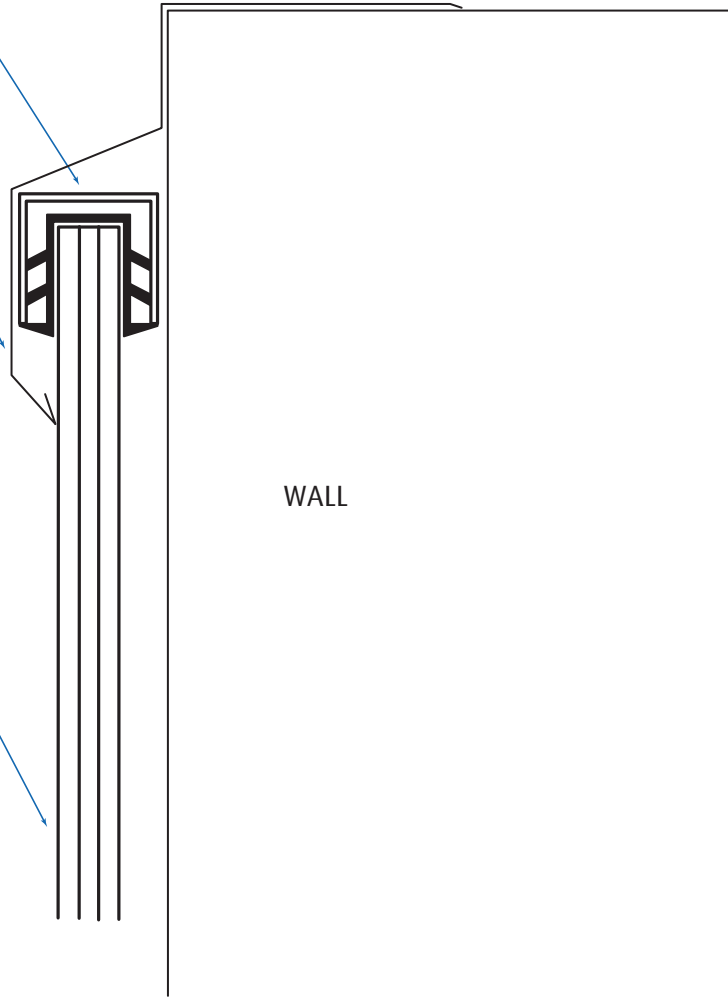

WALL



Lexan Thermoclear 10mm & 16mm Wall Detail

May 2011

DRAWN - MM

© Ampelite 2011

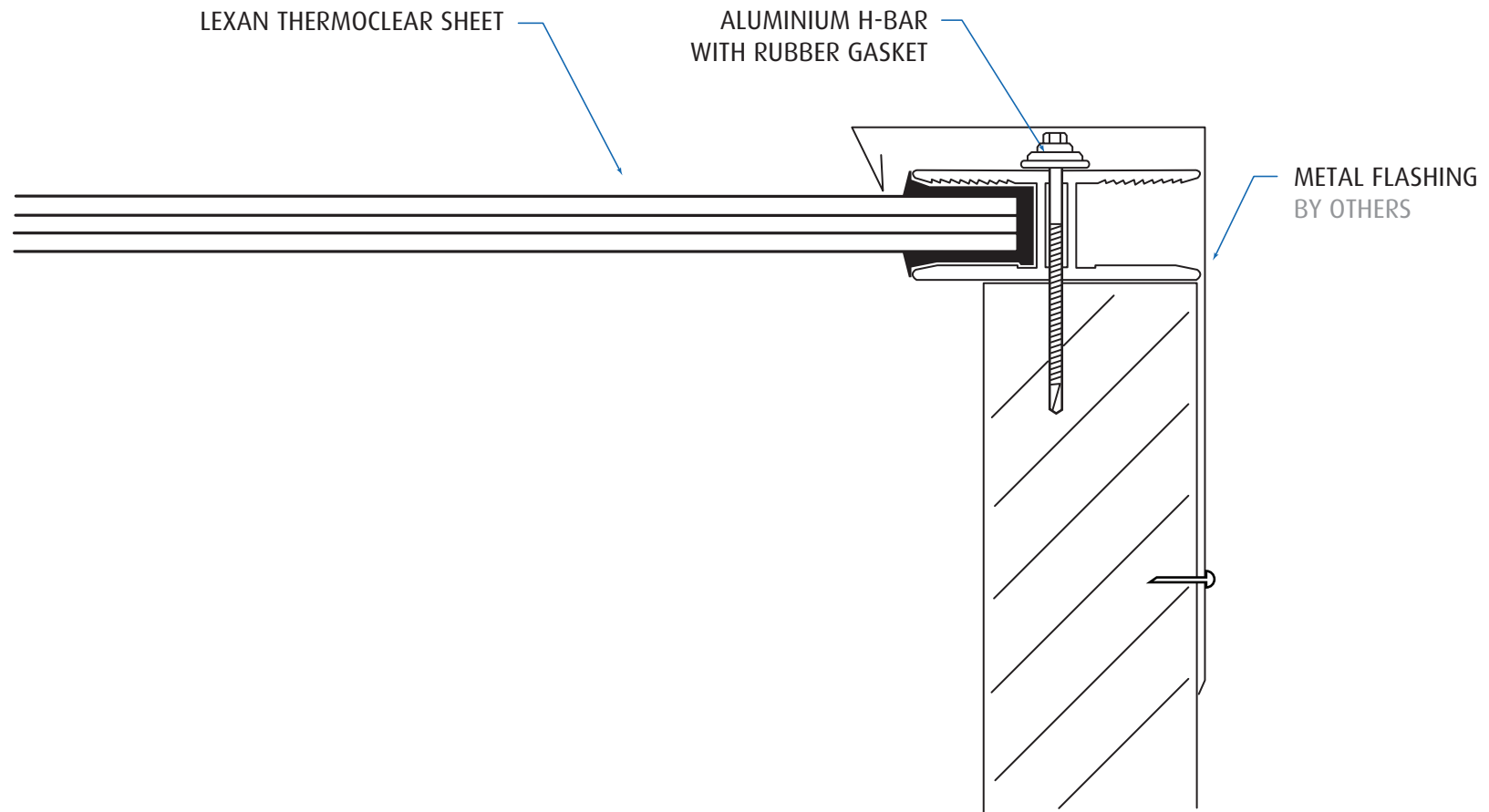

Lexan Thermoclear 10mm & 16mm Corner Flashing Detail

May 2011

DRAWN - MM

© Ampelite 2011

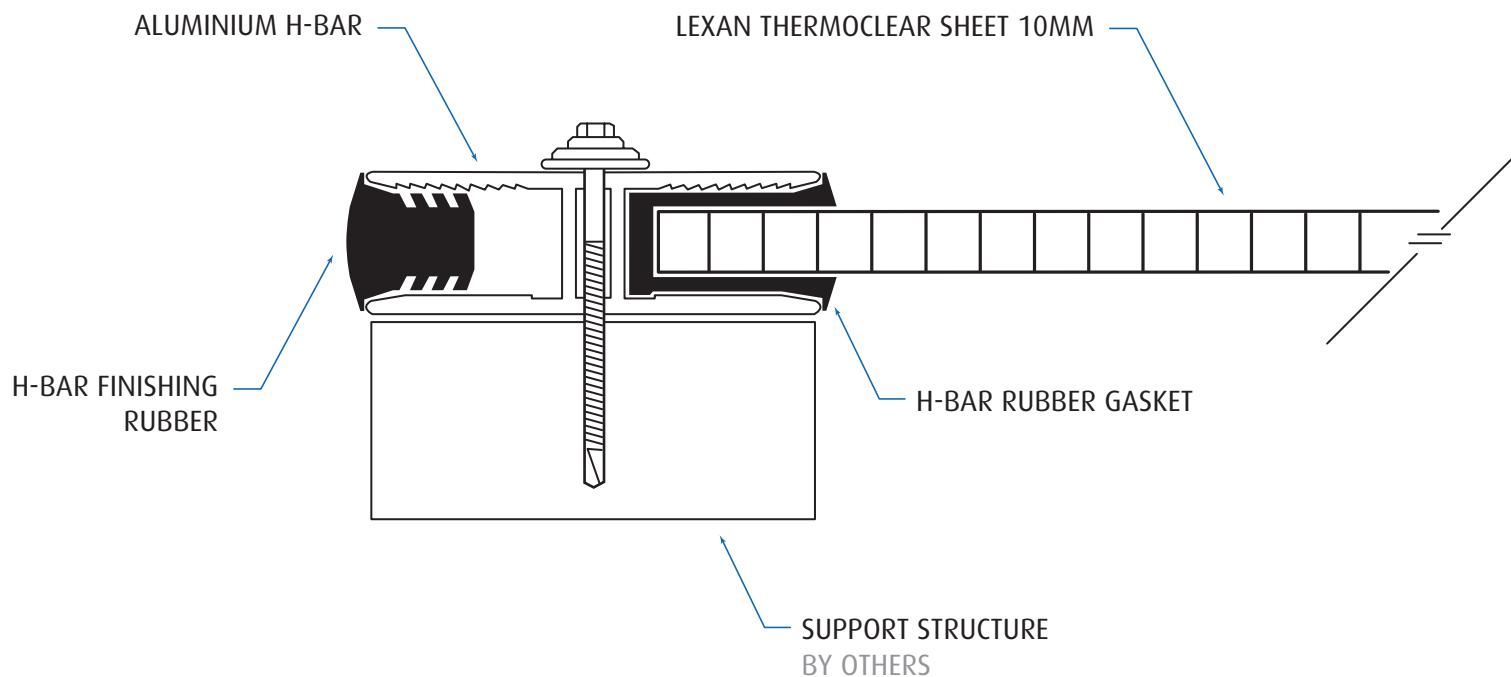

Lexan Thermoclear 10mm H-Bar Finishing Rubber Detail

May 2011

DRAWN - MM

© Ampelite 2011

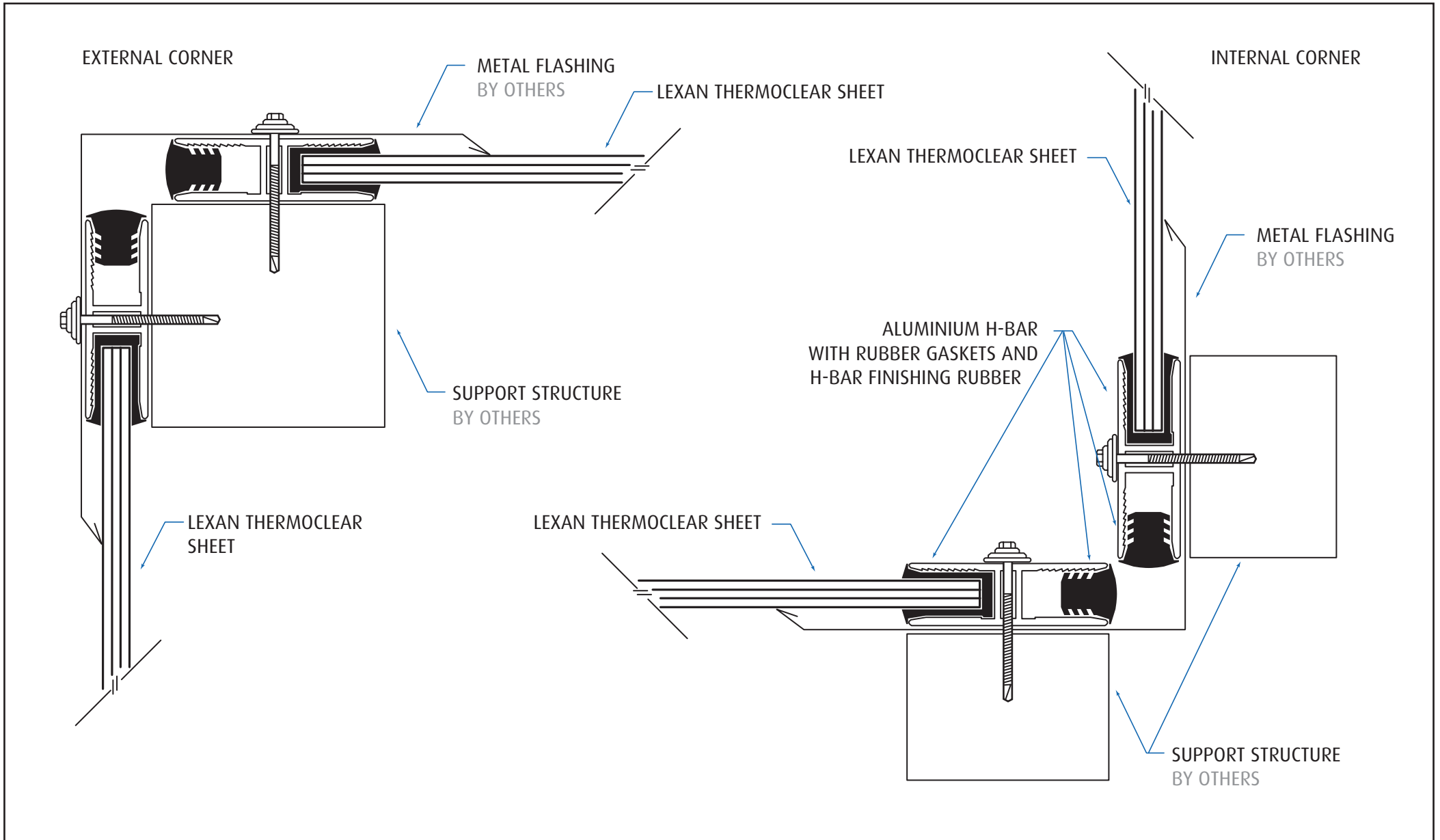

Lexan Thermoclear 10mm & 16mm Corner Detail

May 2011

DRAWN - MM

© Ampelite 2011

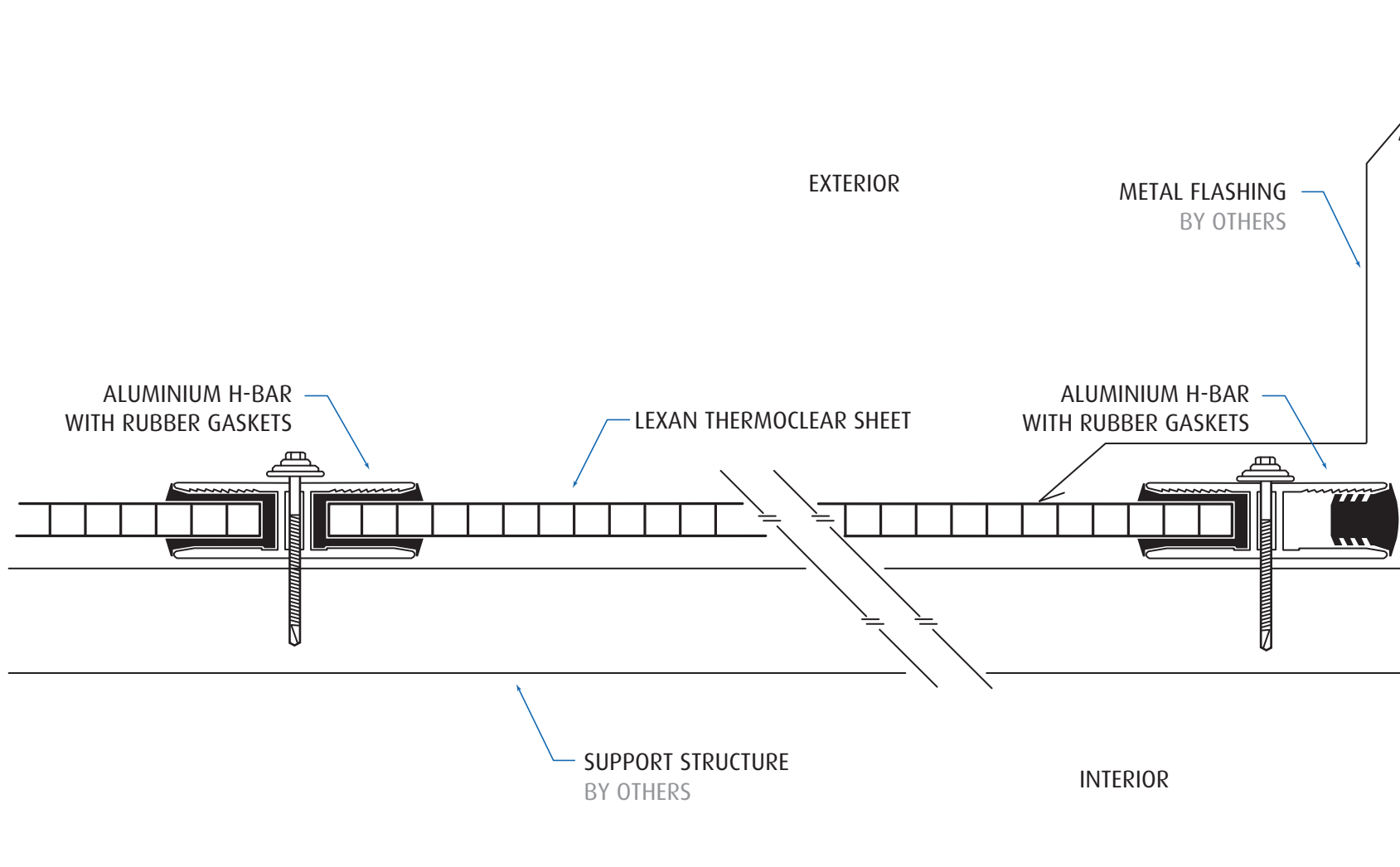

Lexan Thermoclear 10mm & 16mm Flashing Detail Roof - Purlin Support

May 2011

DRAWN - MM

© Ampelite 2011

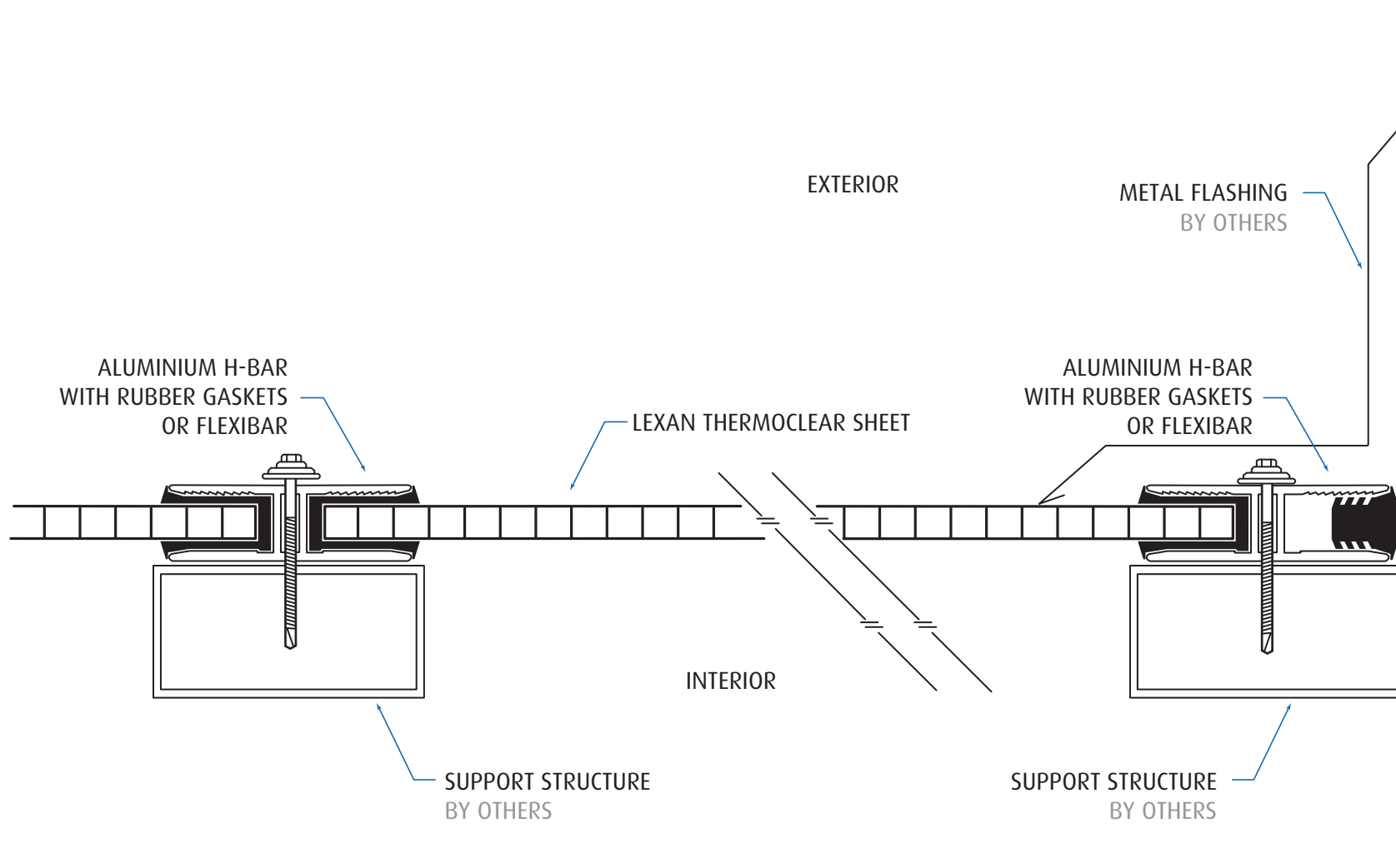

Lexan Thermoclear 10mm & 16mm Flashing Detail Roof - Full Rafter Support

May 2011

DRAWN - MM

© Ampelite 2011

END CAP 10MM & 16MM

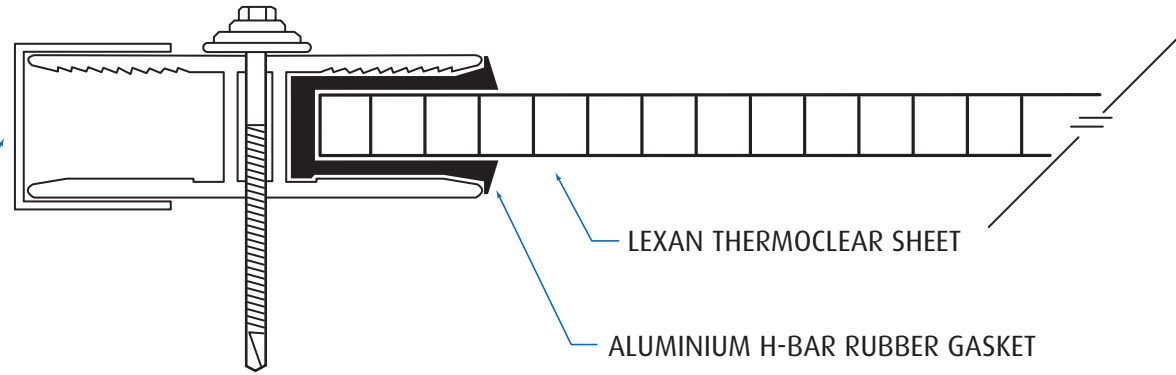

LEXAN THERMOCLEAR SHEET

ALUMINIUM H-BAR RUBBER GASKET

H-BAR FINISHING RUBBER 10MM

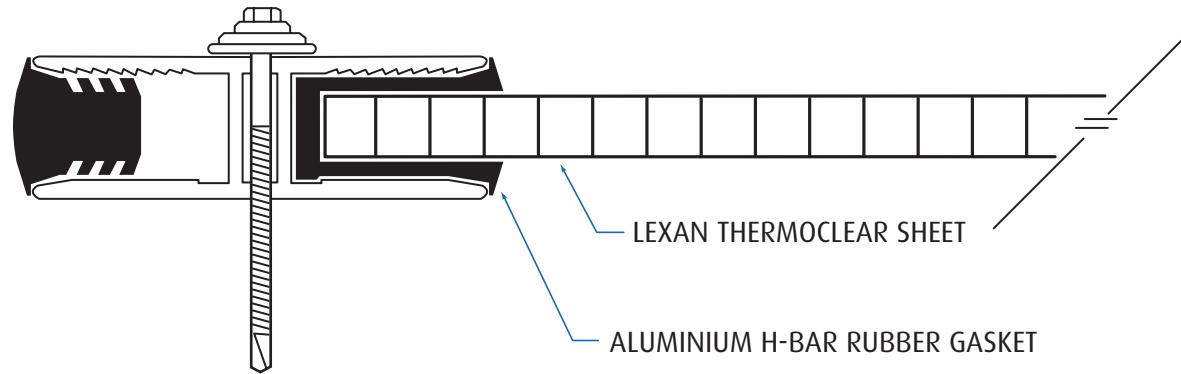

LEXAN THERMOCLEAR SHEET

ALUMINIUM H-BAR RUBBER GASKET

CUSTOM FLASHING
BY OTHERS

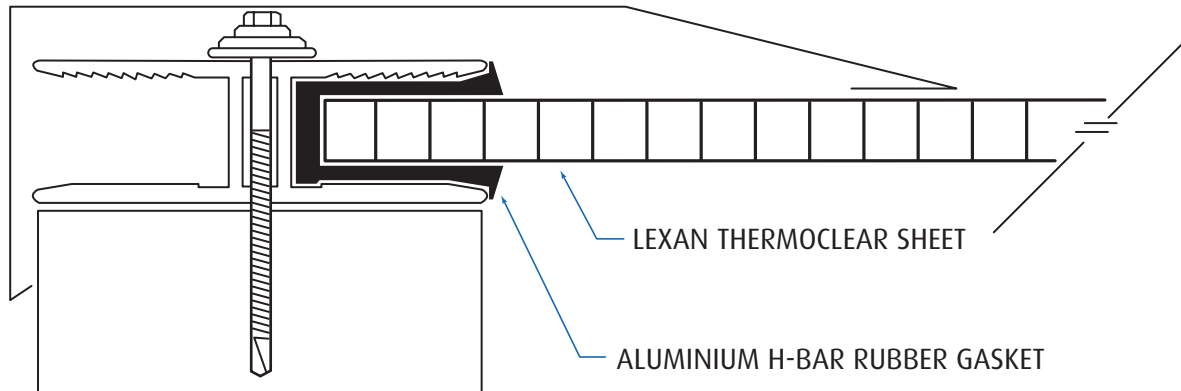

LEXAN THERMOCLEAR SHEET

ALUMINIUM H-BAR RUBBER GASKET



Lexan Thermoclear 10mm & 16mm Barge Detail Options

May 2011

DRAWN - MM

© Ampelite 2011